

**ACCADO®**  
AKSESUAR SİSTEMLERİ



ACCADO was established in Antalya in 2009 for unconditional satisfaction of PVC windows and doors sector clients in TURKEY. The total area of the factory is in the excess of 8000 m<sup>2</sup>.

High levels of investment in technology and skilled employee is made in order to meet the demand of both domestic and foreign customers. Consistent high quality production, wide range of products, skilled technical support and the development of the modern logistics infrastructure assures the brand to hold a strong position among its competitors.

The production of the Tilt and Turn System starts at the end of the year 2010. With the new products and the automated manufacturing process the total area of the company reaches to 15.000. m<sup>2</sup> and a workforce of 300 employees.

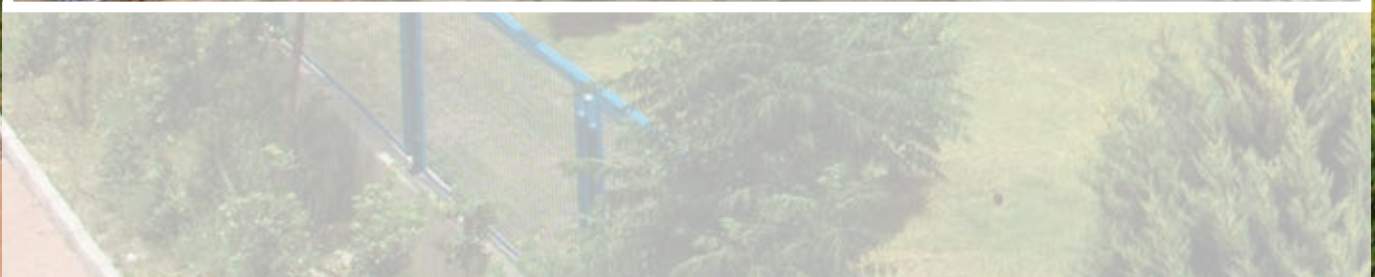



ACCADO established a large-scale integrated factory in order to become the “leader” of manufacturing and sale of window and door fittings and accessories and continues manufacturing with its zinc-aluminium die-cast, sheet metal punching and bending (machines between 20 tons - 300 tons), plastic injection, electrostatic powder coating, wet painting and galvanic zinc coating departments.

The company is also granted with TSE certificates and also started the procedure of ISO 9001 and ISO 9000 certification.



• **VISION**

“High Quality” - this is the first association that should arise from consumers at the mention of our brand. ACCADO as the brand with its “High Quality” is going to settle on the world market as an immortal brand.

• **MISSION**

Providing high quality products and services equally to domestic and foreign consumers. Mentioned accessories ACCADO worldwide should be associated with high-tech products and professional service.

• **EXPORT**

Due to the latest technologies for producing accessories for windows and doors, ACCADO becomes a well known global brand and now is exporting to 26 countries.

In addition, many foreign trading companies operating in Turkey, send our products to their countries.

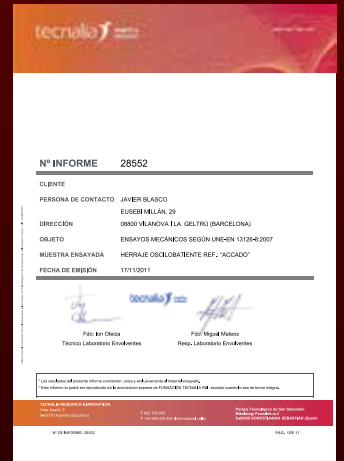

• **QUALITY POLICY**

ACCADO, which produce accessories for PVC windows and doors, create a new policy of quality management.

The principles of this policy:

With the joint participation of all our employees,

In collaboration with our customers,

Efficient use of resources  
Compliance with national and international standards, without prejudice to our products and with high quality services

Conscious of continuous improvement and development, Provide a high level of customer satisfaction.

**Our company continues to develop its business and expanding our product range in the following directions;**

- Aluminum handle groups
- Zink connection elements
- Tilt and turn system
- Side hung gears and door lock espagnolettes
- Sliding runners, steel fasteners, plastic products.

ACCADO doesn't do any difference between domestic and foreign market, provides high quality products and services on the way to world fame "produces accessories for windows and doors."



# Tilt & Turn Systems



# Tilt & Turn Product Table

## GV - Vertical Tilt

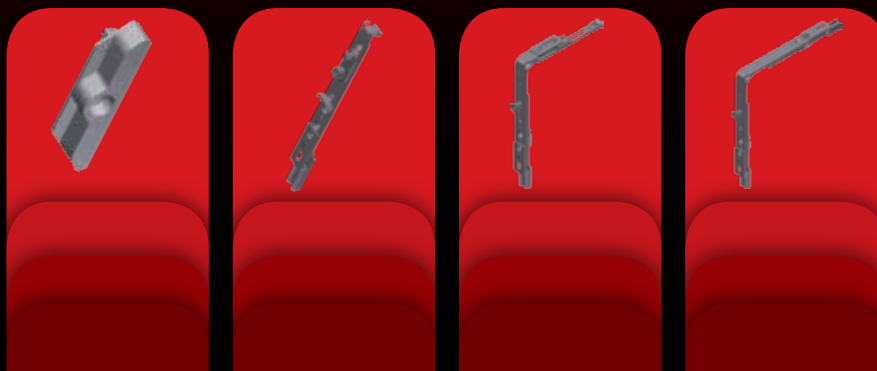
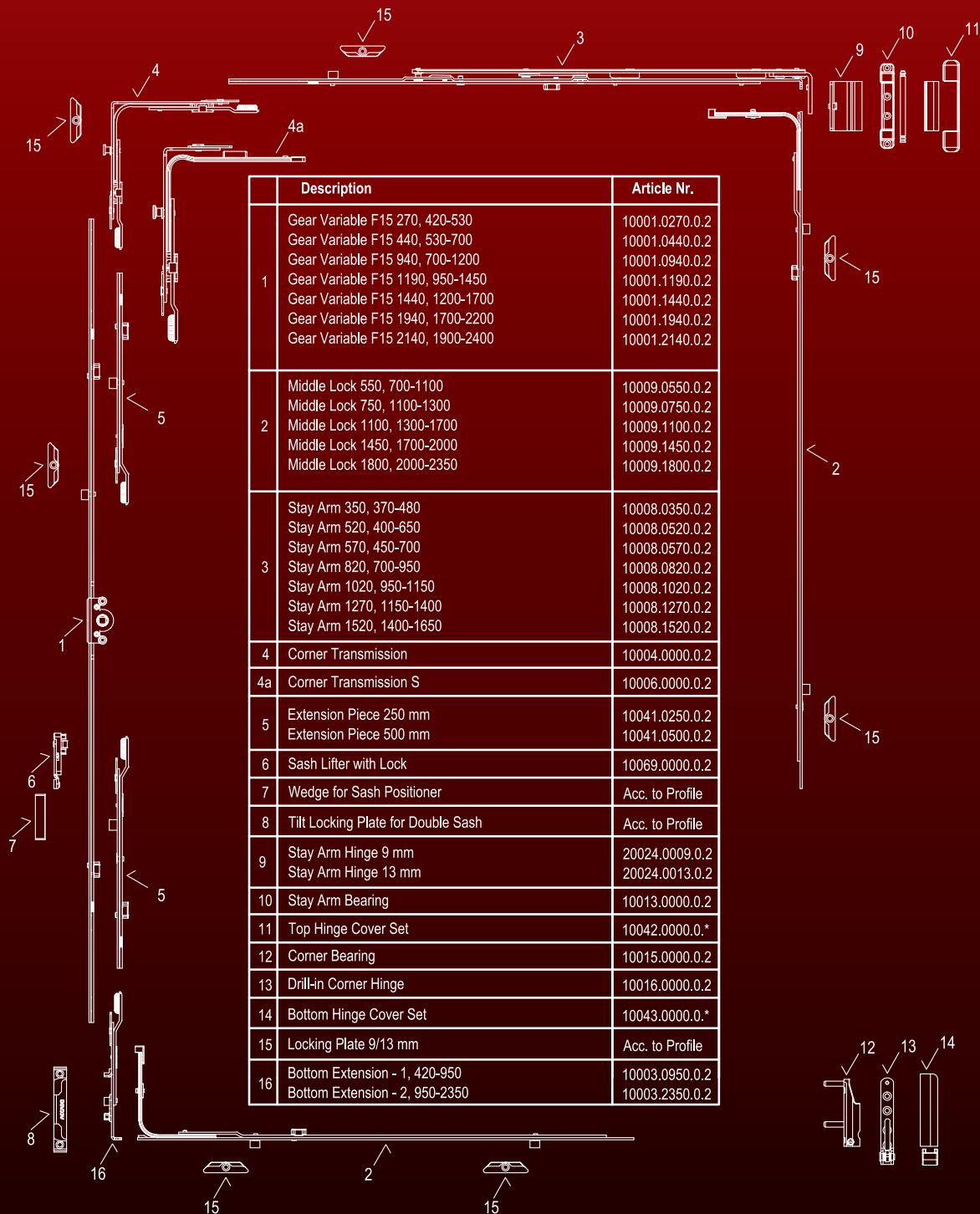



# Tilt & Turn Product Table

## GV - Se - Horizontal Tilt

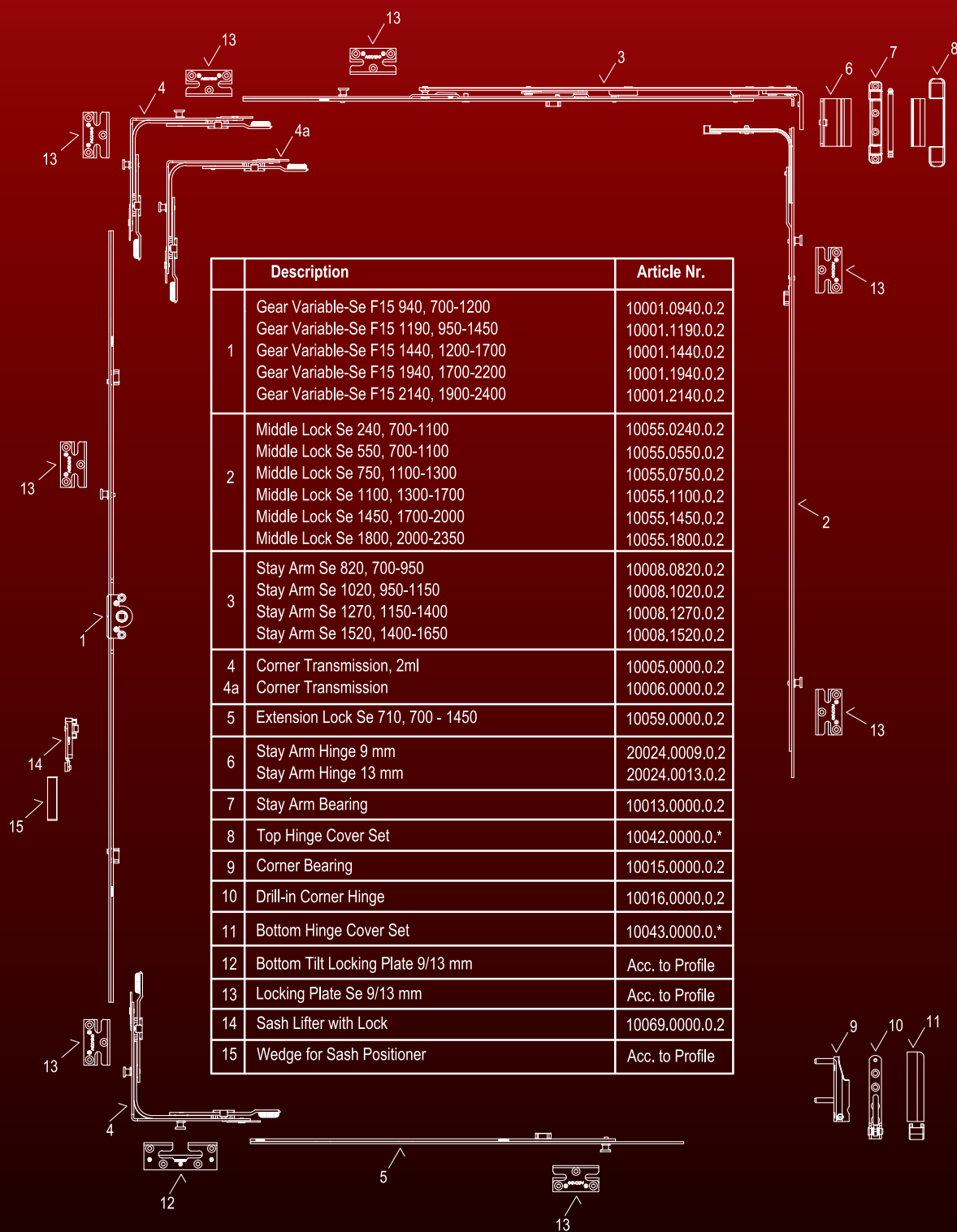

	Description	Article Nr.
1	Gear Variable-Se F15 940, 700-1200	10001.0940.0.2
	Gear Variable-Se F15 1190, 950-1450	10001.1190.0.2
	Gear Variable-Se F15 1440, 1200-1700	10001.1440.0.2
	Gear Variable-Se F15 1940, 1700-2200	10001.1940.0.2
	Gear Variable-Se F15 2140, 1900-2400	10001.2140.0.2
2	Middle Lock Se 240, 700-1100	10055.0240.0.2
	Middle Lock Se 550, 700-1100	10055.0550.0.2
	Middle Lock Se 750, 1100-1300	10055.0750.0.2
	Middle Lock Se 1100, 1300-1700	10055.1100.0.2
	Middle Lock Se 1450, 1700-2000	10055.1450.0.2
	Middle Lock Se 1800, 2000-2350	10055.1800.0.2
3	Stay Arm Se 820, 700-950	10008.0820.0.2
	Stay Arm Se 1020, 950-1150	10008.1020.0.2
	Stay Arm Se 1270, 1150-1400	10008.1270.0.2
	Stay Arm Se 1520, 1400-1650	10008.1520.0.2
4	Corner Transmission, 2ml	10005.0000.0.2
4a	Corner Transmission	10006.0000.0.2
5	Extension Lock Se 710, 700 - 1450	10059.0000.0.2
6	Stay Arm Hinge 9 mm	20024.0009.0.2
	Stay Arm Hinge 13 mm	20024.0013.0.2
7	Stay Arm Bearing	10013.0000.0.2
8	Top Hinge Cover Set	10042.0000.0.*
9	Corner Bearing	10015.0000.0.2
10	Drill-in Corner Hinge	10016.0000.0.2
11	Bottom Hinge Cover Set	10043.0000.0.*
12	Bottom Tilt Locking Plate 9/13 mm	Acc. to Profile
13	Locking Plate Se 9/13 mm	Acc. to Profile
14	Sash Lifter with Lock	10069.0000.0.2
15	Wedge for Sash Positioner	Acc. to Profile

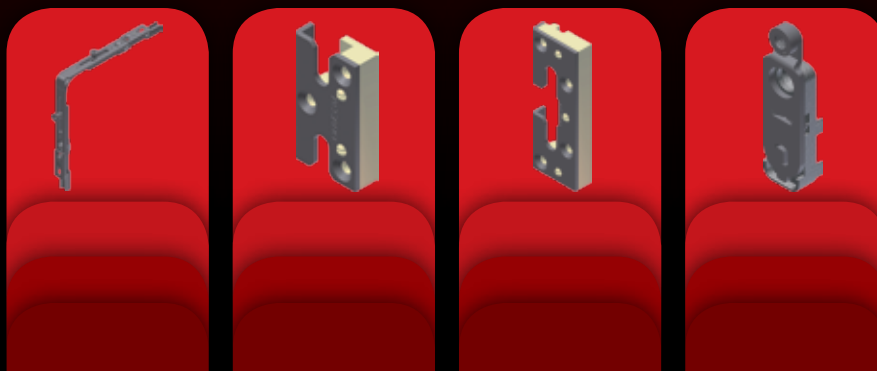



# Tilt & Turn Product Table

## GV - Micro Ventilation - Horizontal Tilt

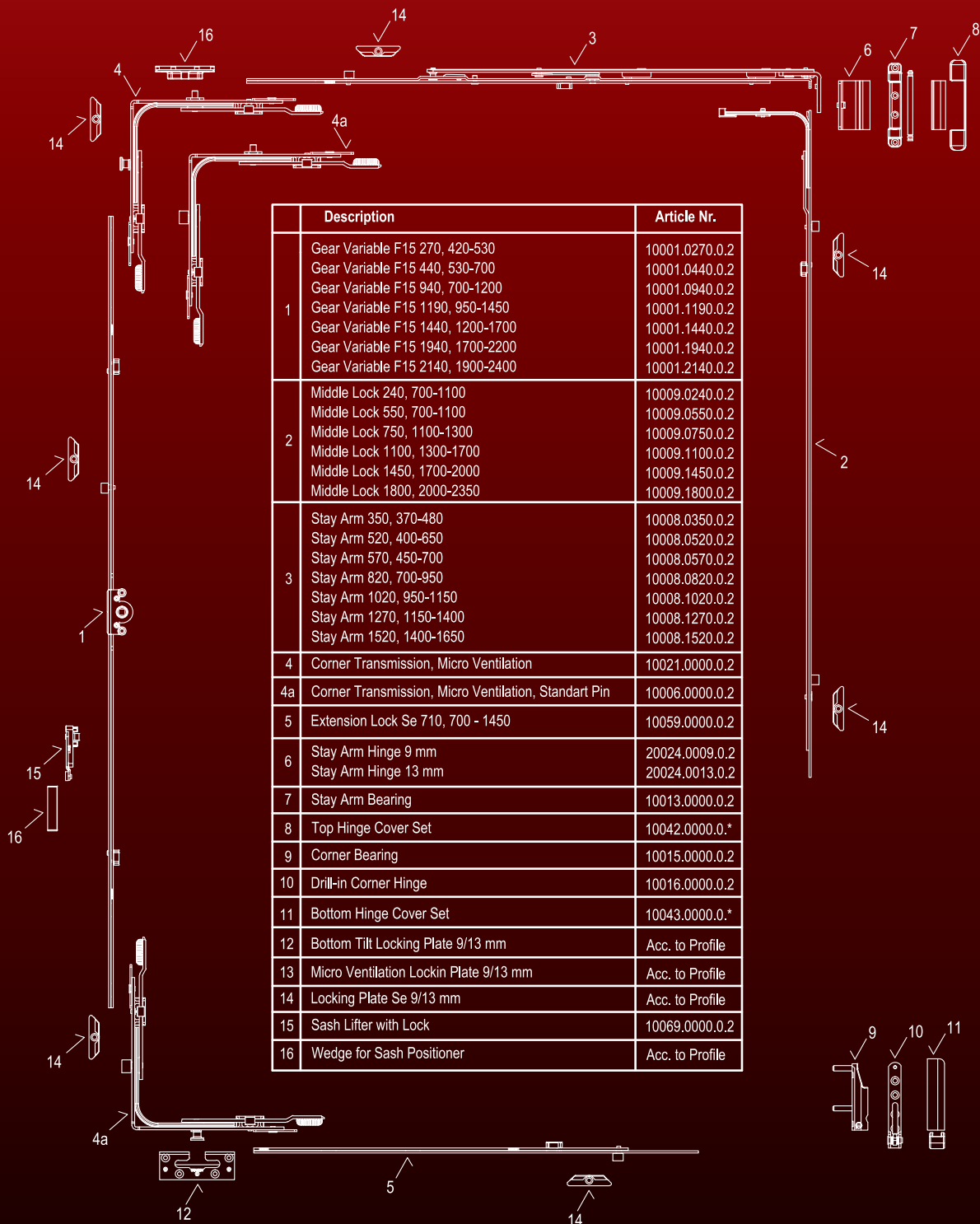

	Description	Article Nr.
1	Gear Variable F15 270, 420-530	10001.0270.0.2
	Gear Variable F15 440, 530-700	10001.0440.0.2
	Gear Variable F15 940, 700-1200	10001.0940.0.2
	Gear Variable F15 1190, 950-1450	10001.1190.0.2
	Gear Variable F15 1440, 1200-1700	10001.1440.0.2
	Gear Variable F15 1940, 1700-2200	10001.1940.0.2
	Gear Variable F15 2140, 1900-2400	10001.2140.0.2
2	Middle Lock 240, 700-1100	10009.0240.0.2
	Middle Lock 550, 700-1100	10009.0550.0.2
	Middle Lock 750, 1100-1300	10009.0750.0.2
	Middle Lock 1100, 1300-1700	10009.1100.0.2
	Middle Lock 1450, 1700-2000	10009.1450.0.2
	Middle Lock 1800, 2000-2350	10009.1800.0.2
3	Stay Arm 350, 370-480	10008.0350.0.2
	Stay Arm 520, 400-650	10008.0520.0.2
	Stay Arm 570, 450-700	10008.0570.0.2
	Stay Arm 820, 700-950	10008.0820.0.2
	Stay Arm 1020, 950-1150	10008.1020.0.2
	Stay Arm 1270, 1150-1400	10008.1270.0.2
	Stay Arm 1520, 1400-1650	10008.1520.0.2
4	Corner Transmission, Micro Ventilation	10021.0000.0.2
4a	Corner Transmission, Micro Ventilation, Standart Pin	10006.0000.0.2
5	Extension Lock Se 710, 700 - 1450	10059.0000.0.2
6	Stay Arm Hinge 9 mm	20024.0009.0.2
	Stay Arm Hinge 13 mm	20024.0013.0.2
7	Stay Arm Bearing	10013.0000.0.2
8	Top Hinge Cover Set	10042.0000.0.*
9	Corner Bearing	10015.0000.0.2
10	Drill-in Corner Hinge	10016.0000.0.2
11	Bottom Hinge Cover Set	10043.0000.0.*
12	Bottom Tilt Locking Plate 9/13 mm	Acc. to Profile
13	Micro Ventilation Lockin Plate 9/13 mm	Acc. to Profile
14	Locking Plate Se 9/13 mm	Acc. to Profile
15	Sash Lifter with Lock	10069.0000.0.2
16	Wedge for Sash Positioner	Acc. to Profile

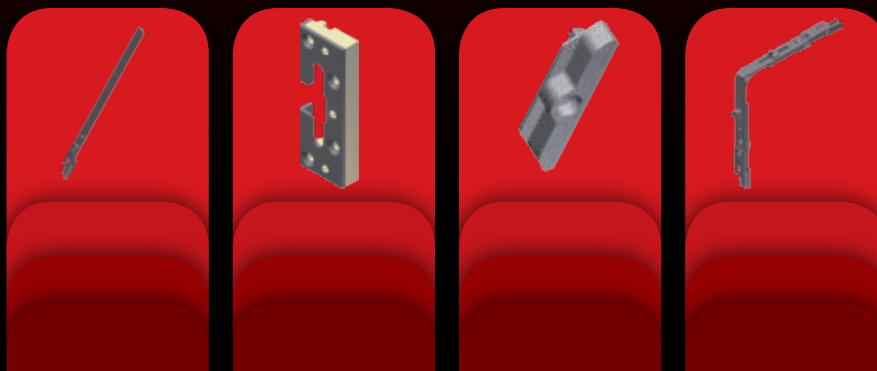

# Tilt & Turn Product Table

## GC - Horizontal Tilt

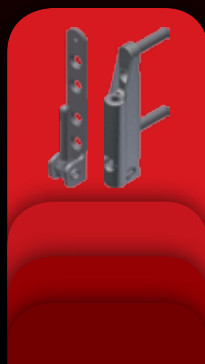
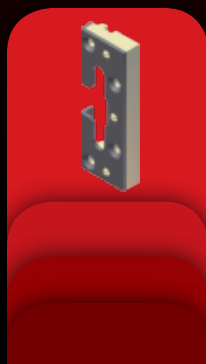
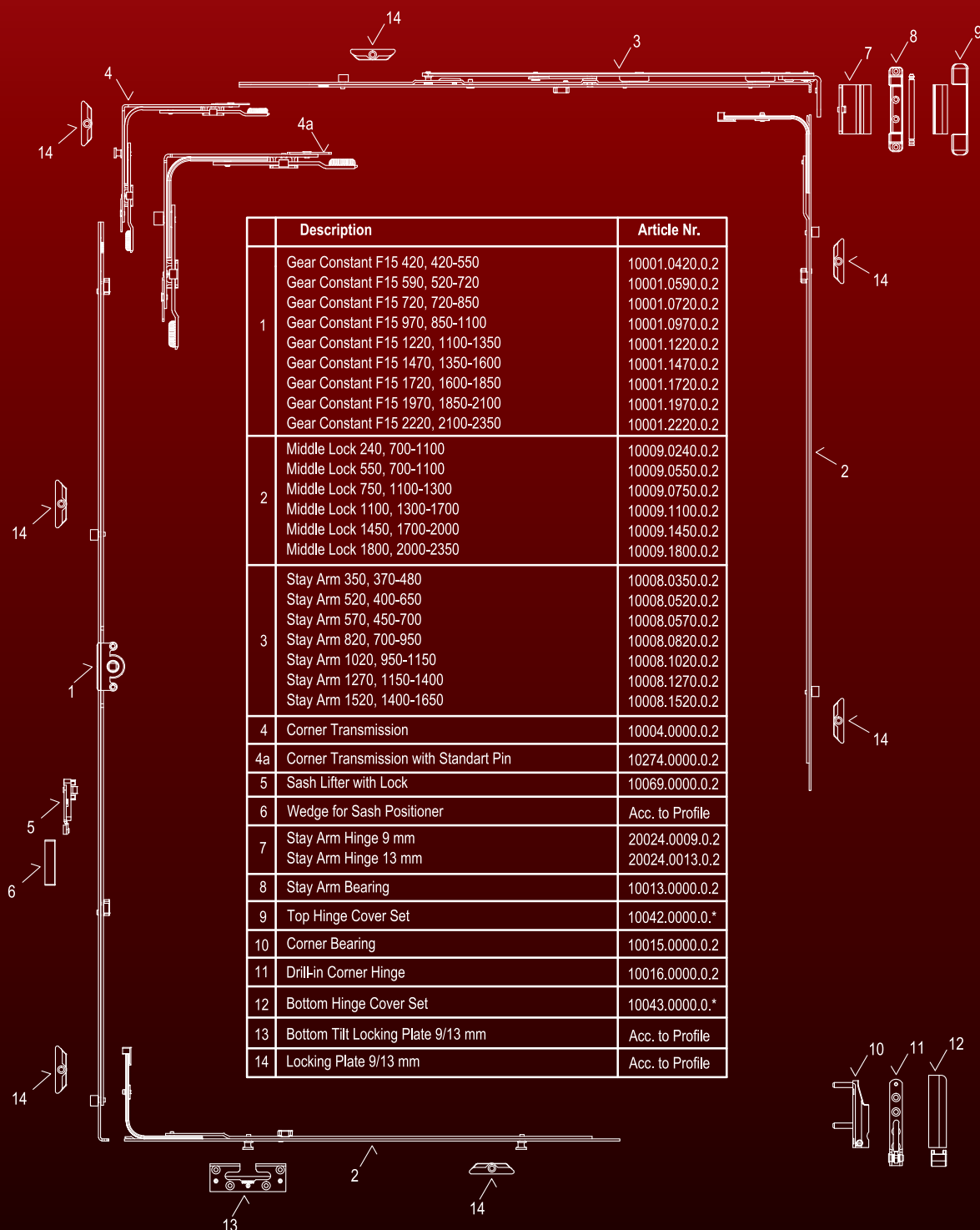

# Double Sash Systems



# Double Sash Product Table

## GV - Rebate Lever & Shoot Bolt System

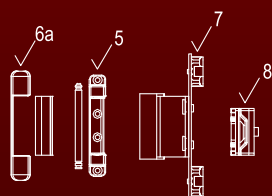
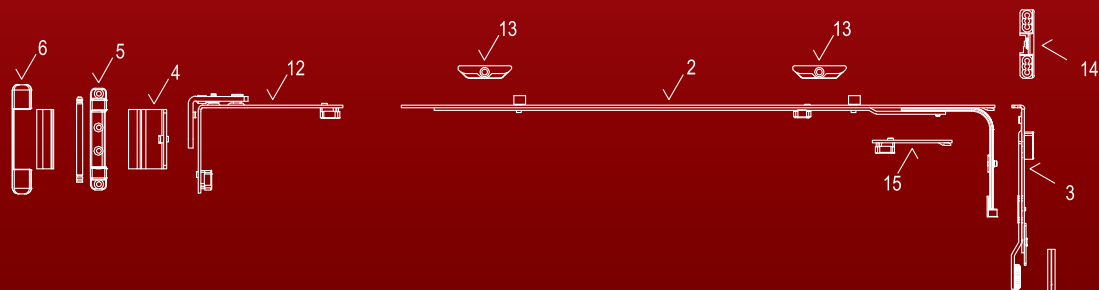

	Description	Article Nr.
1	Rebate Lever Variable 940, 720-1200	10010.0940.0.2
	Rebate Lever Variable 1190, 950-1450	10010.1190.0.2
	Rebate Lever Variable 1440, 1200-1700	10010.1440.0.2
	Rebate Lever Variable 1940, 1700-2200	10010.1940.0.2
2	Middle Lock 550, 700-1100	10009.0550.0.2
	Middle Lock 750, 1100-1300	10009.0750.0.2
	Middle Lock 1100, 1300-1700	10009.1100.0.2
	Middle Lock 1450, 1700-2000	10009.1450.0.2
	Middle Lock 1800, 2000-2350	10009.1800.0.2
3	Shoot Bolt Top	10011.0000.0.2
	Shoot Bolt Bottom	10012.0000.0.2
4	Stay Arm Hinge 9 mm	20024.0009.0.2
	Stay Arm Hinge 13 mm	20024.0013.0.2
5	Stay Arm Bearing	10013.0000.0.2
6	Top Hinge Cover Set	10042.0000.0.*
6a	Adjustable Middle Hinge Cover Set	10374.0000.0.*
7	Adjustable Middle Hinge 9 mm	10044.0009.0.2
	Adjustable Middle Hinge 13 mm	10044.0013.0.2
8	Middle hinge concealed	10213.0000.0.*
9	Bottom Hinge Cover Set	10043.0000.0.*
10	Corner Bearing	10015.0000.0.2
11	Drill-in Corner Hinge	10016.0000.0.2
12	Adjustable Top Hinge	10022.0000.0.2
13	Locking Plate 9/13 mm	Acc. to Profile
14	Locking Plate for Shoot Bolt 9/13 mm	Acc. to Profile
15	Fixing Plate	10062.0000.0.2

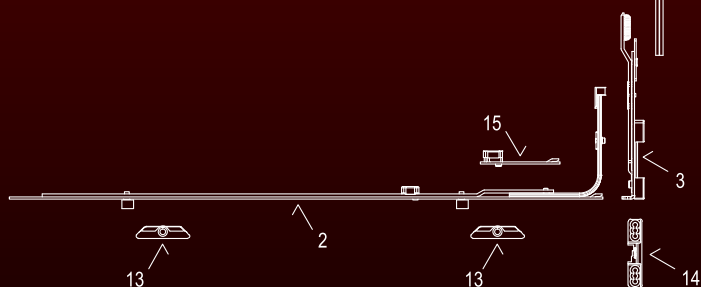
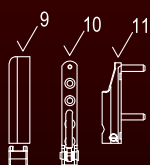



# Double Sash Product Table

## Shoot Bolt with Lever

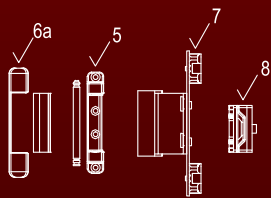
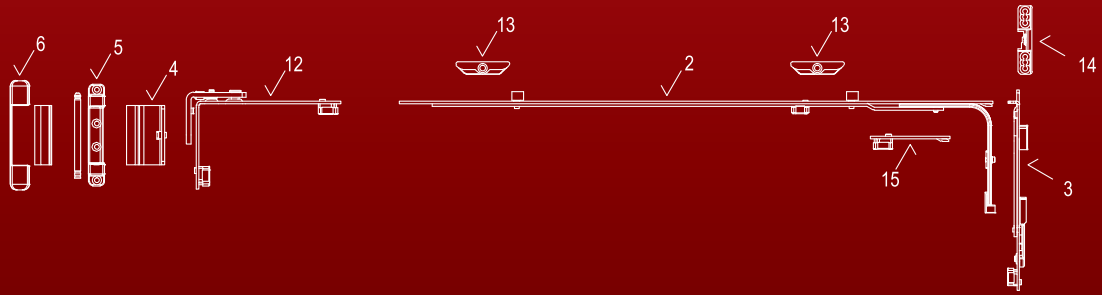

	Description	Article Nr.
1	Rebate Locking Plate	20146.0000.0.2
2	Middle Lock 550, 700-1100 Middle Lock 750, 1100-1300 Middle Lock 1100, 1300-1700	10009.0550.0.2 10009.0750.0.2 10009.1100.0.2
3	Shoot Bolt Top Shoot Bolt Bottom	10011.0000.0.2 10012.0000.0.2
4	Stay Arm Hinge 9 mm Stay Arm Hinge 13 mm	20024.0009.0.2 20024.0013.0.2
5	Stay Arm Bearing	10013.0000.0.2
6	Top Hinge Cover Set	10042.0000.0.*
6a	Adjustable Middle Hinge Cover Set	10374.0000.0.*
7	Adjustable Middle Hinge 9 mm Adjustable Middle Hinge 13 mm	10044.0009.0.2 10044.0013.0.2
8	Middle hinge concealed	10213.0000.0.*
9	Bottom Hinge Cover Set	10043.0000.0.*
10	Corner Bearing	10015.0000.0.2
11	Drill-in Corner Hinge	10016.0000.0.2
12	Adjustable Top Hinge	10022.0000.0.2
13	Locking Plate 9/13 mm	Acc. to Profile
14	Locking Plate for Shoot Bolt 9/13 mm	Acc. to Profile
15	Fixing Plate	10062.0000.0.2

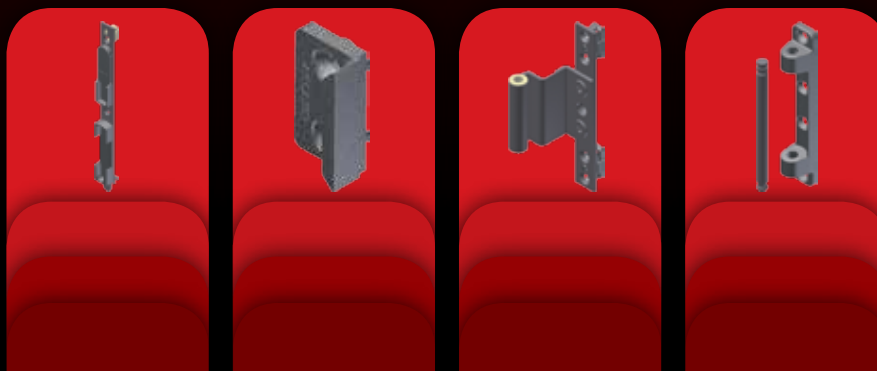
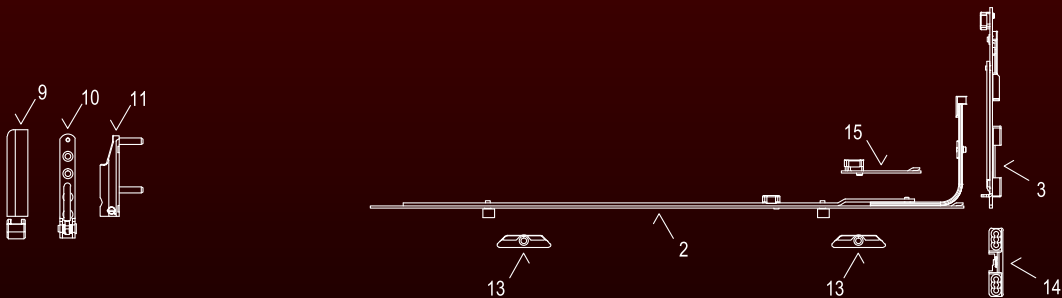

# Turn-Only / Tilt-Only Systems

# Turn-Only / Tilt-Only Product Table

## Symmetrical Hinge Assembly

1	Gear Variable F15 270, 420-530	10001.0270.0.2
	Gear Variable F15 440, 530-700	10001.0440.0.2
	Gear Variable F15 940, 700-1200	10001.0940.0.2
	Gear Variable F15 1190, 950-1450	10001.1190.0.2
	Gear Variable F15 1440, 1200-1700	10001.1440.0.2
	Gear Variable F15 1940, 1700-2200	10001.1940.0.2
	Gear Variable F15 2140, 1900-2400	10001.2140.0.2
2	Middle Lock 550, 700-1100	10009.0550.0.2
	Middle Lock 750, 1100-1300	10009.0750.0.2
	Middle Lock 1100, 1300-1700	10009.1100.0.2
	Middle Lock 1450, 1700-2000	10009.1450.0.2
	Middle Lock 1800, 2000-2350	10009.1800.0.2
3	Stay Arm Hinge 9 mm	20024.0009.0.2
	Stay Arm Hinge 13 mm	20024.0013.0.2
4	Stay Arm Bearing	10013.0000.0.2
5	Top Hinge Cover Set	10042.0000.0.*
5a	Adjustable Middle Hinge Cover Set	10374.0000.0.*
6	Adjustable Middle Hinge 9 mm	10044.0009.0.2
	Adjustable Middle Hinge 13 mm	10044.0013.0.2
7	Middle hinge concealed	10213.0000.0.*
8	Bottom Hinge Cover Set	10043.0000.0.*
9	Corner Bearing	10015.0000.0.2
10	Drill-in Corner Hinge	10016.0000.0.2
11	Adjustable Top Hinge	10022.0000.0.2
12	Locking Plate 9/13 mm	Acc. to Profile
13	Extension Piece, 180°	10040.0000.0.2

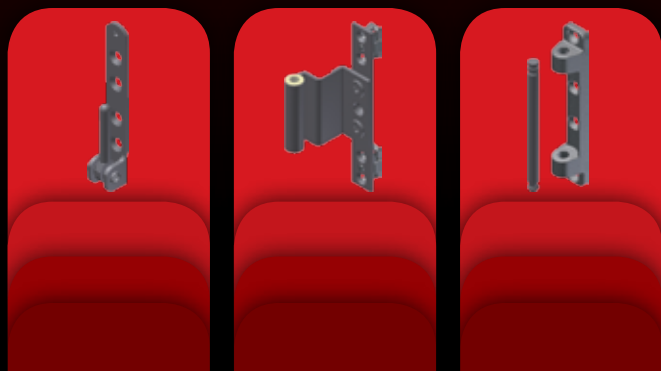

# Turn-Only / Tilt-Only Product Table

## Symmetrical Hinge Assembly

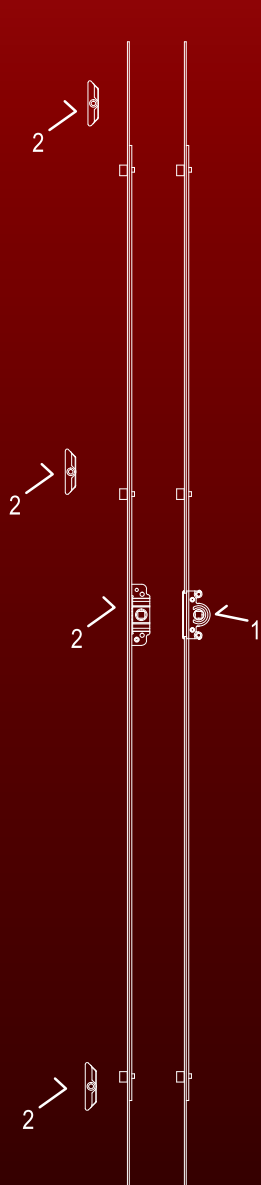

	Description	Article Nr.
1	Tilt-Only / Turn Only Espagnolette, 15 mm Backset, Zinc Gear 280, 280-400	10070.0280.0.2
	Tilt-Only / Turn Only Espagnolette, 15 mm Backset, Zinc Gear 600, 500-800	10070.0600.0.2
	Tilt-Only / Turn Only Espagnolette, 15 mm Backset, Zinc Gear 800, 700-1200	10070.0800.0.2
	Tilt-Only / Turn Only Espagnolette, 15 mm Backset, Zinc Gear 1000, 900-1200	10070.1000.0.2
	Tilt-Only / Turn Only Espagnolette, 15 mm Backset, Zinc Gear 1200, 1100-1400	10070.1200.0.2
	Tilt-Only / Turn Only Espagnolette, 15 mm Backset, Zinc Gear 1400, 1300-1600	10070.1400.0.2
	Tilt-Only / Turn Only Espagnolette, 15 mm Backset, Zinc Gear 1600, 1500-1800	10070.1600.0.2
	Tilt-Only / Turn Only Espagnolette, 15 mm Backset, Zinc Gear 1800, 1700-2000	10070.1800.0.2
Tilt-Only / Turn Only Espagnolette, 15 mm Backset, Zinc Gear 2000, 1900-2000	10070.2000.0.2	
2	Tilt-Only / Turn Only Espagnolette, 15 mm Backset, Steel Gear 280, 280-400	10071.0280.0.2
	Tilt-Only / Turn Only Espagnolette, 15 mm Backset, Steel Gear 600, 500-800	10071.0600.0.2
	Tilt-Only / Turn Only Espagnolette, 15 mm Backset, Steel Gear 800, 700-1200	10071.0800.0.2
	Tilt-Only / Turn Only Espagnolette, 15 mm Backset, Steel Gear 1000, 900-1200	10071.1000.0.2
	Tilt-Only / Turn Only Espagnolette, 15 mm Backset, Steel Gear 1200, 1100-1400	10071.1200.0.2
	Tilt-Only / Turn Only Espagnolette, 15 mm Backset, Steel Gear 1400, 1300-1600	10071.1400.0.2
	Tilt-Only / Turn Only Espagnolette, 15 mm Backset, Steel Gear 1600, 1500-1800	10071.1600.0.2
	Tilt-Only / Turn Only Espagnolette, 15 mm Backset, Steel Gear 1800, 1700-2000	10071.1800.0.2
Tilt-Only / Turn Only Espagnolette, 15 mm Backset, Steel Gear 2000, 1900-2000	10071.2000.0.2	
3	Stay Arm Hinge 9 mm Stay Arm Hinge 13 mm	20024.0009.0.2 20024.0013.0.2
4	Stay Arm Bearing	10013.0000.0.2
5	Top Hinge Cover Set	10042.0000.0.*
5a	Adjustable Middle Hinge Cover Set	10374.0000.0.*
6	Adjustable Middle Hinge 9 mm Adjustable Middle Hinge 13 mm	10044.0009.0.2 10044.0013.0.2
7	Middle hinge concealed	10213.0000.0.*
8	Bottom Hinge Cover Set	10043.0000.0.*
9	Corner Bearing	10015.0000.0.2
10	Drill-in Corner Hinge	10016.0000.0.2
11	Adjustable Top Hinge	10022.0000.0.2
12	Locking Plate 9/13 mm	Acc. to Profile

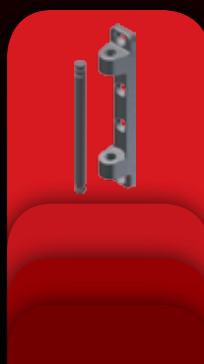
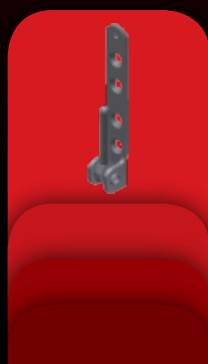
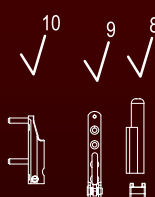
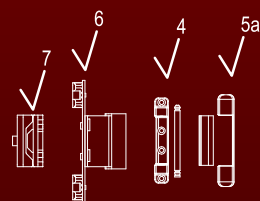
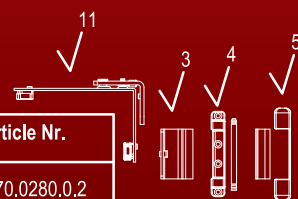



**Espagnolettes**



# Tilt-Only / Turn Only Espagnolette, 15 mm Backset, Steel Gear

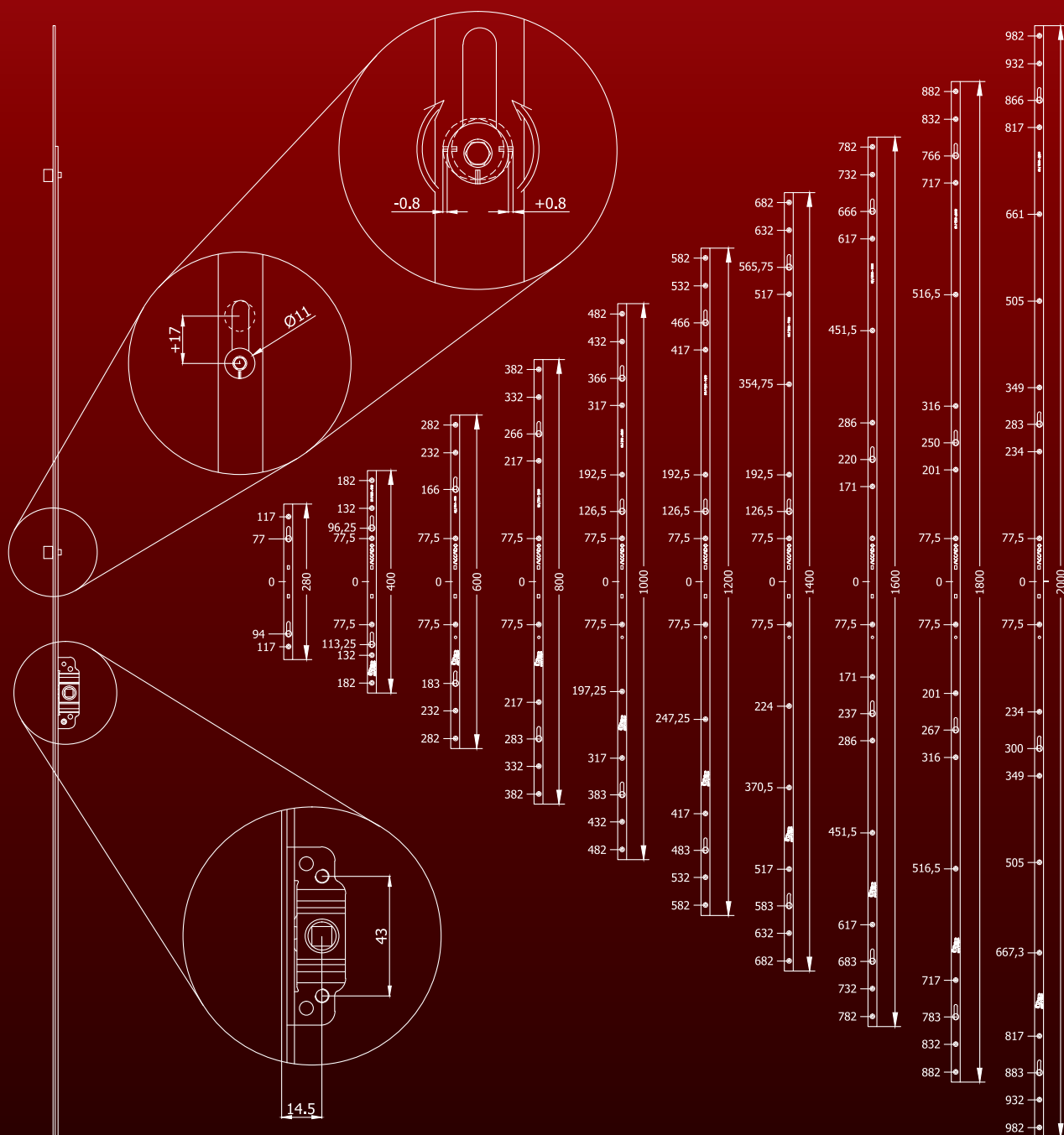

Description	Article Nr.
Tilt-Only / Turn Only Espagnolette, 15 mm Backset, Steel Gear 280, 280-400	10071.0280.0.2
Tilt-Only / Turn Only Espagnolette, 15 mm Backset, Steel Gear 400, 300-600	10071.0400.0.2
Tilt-Only / Turn Only Espagnolette, 15 mm Backset, Steel Gear 600, 500-800	10071.0600.0.2
Tilt-Only / Turn Only Espagnolette, 15 mm Backset, Steel Gear 800, 700-1200	10071.0800.0.2
Tilt-Only / Turn Only Espagnolette, 15 mm Backset, Steel Gear 1000, 900-1200	10071.1000.0.2
Tilt-Only / Turn Only Espagnolette, 15 mm Backset, Steel Gear 1200, 1100-1400	10071.1200.0.2
Tilt-Only / Turn Only Espagnolette, 15 mm Backset, Steel Gear 1400, 1300-1600	10071.1400.0.2
Tilt-Only / Turn Only Espagnolette, 15 mm Backset, Steel Gear 1600, 1500-1800	10071.1600.0.2
Tilt-Only / Turn Only Espagnolette, 15 mm Backset, Steel Gear 1800, 1700-2000	10071.1800.0.2
Tilt-Only / Turn Only Espagnolette, 15 mm Backset, Steel Gear 2000, 1900-2000	10071.2000.0.2

# Tilt-Only / Turn Only Espagnolette, 15 mm Backset, Steel Gear

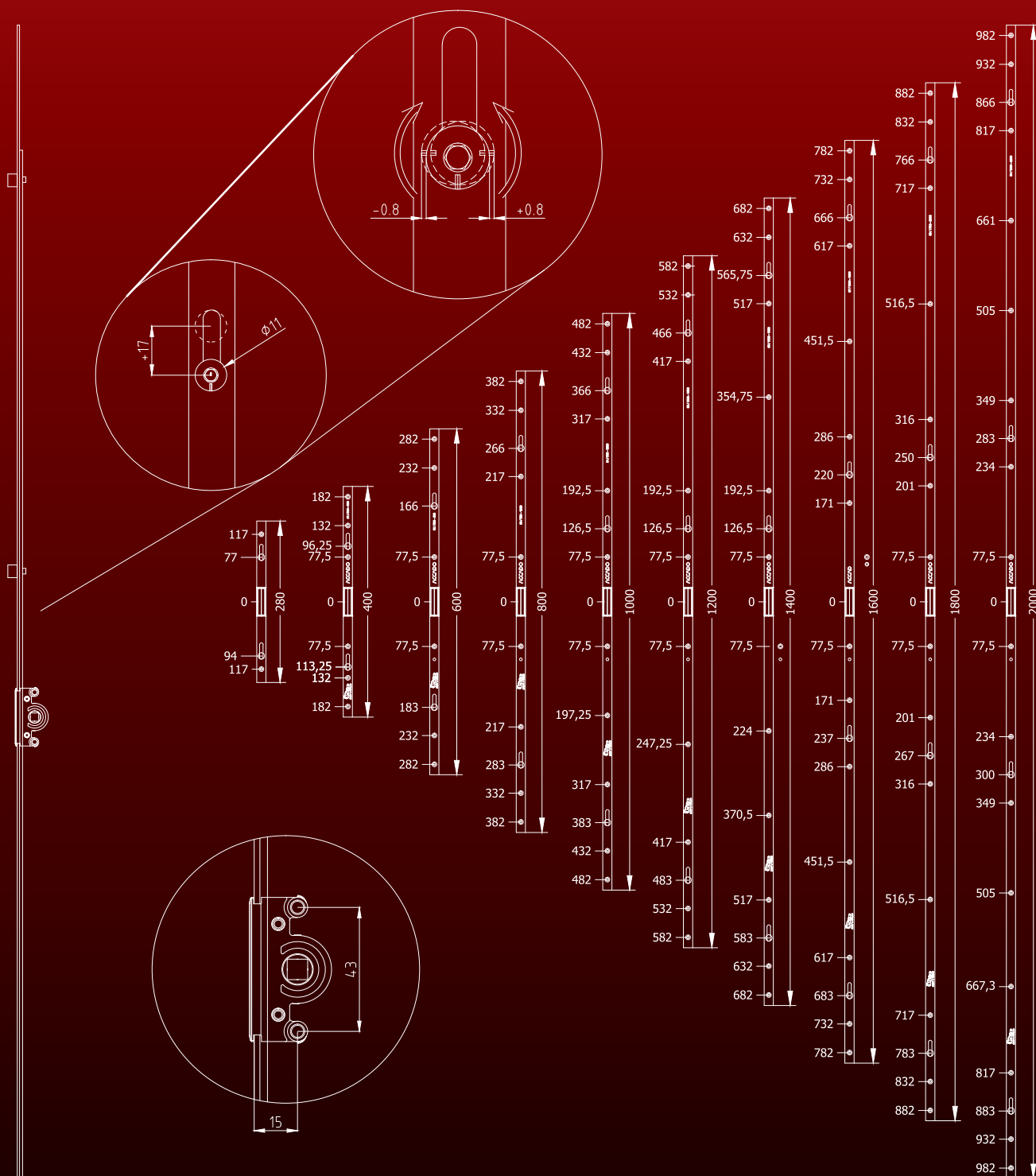

Description	Article Nr.
Tilt-Only / Turn Only Espagnolette, 15 mm Backset, Zinc Gear 280, 280-400	10070.0280.0.2
Tilt-Only / Turn Only Espagnolette, 15 mm Backset, Zinc Gear 400, 300-600	10070.0400.0.2
Tilt-Only / Turn Only Espagnolette, 15 mm Backset, Zinc Gear 600, 500-800	10070.0600.0.2
Tilt-Only / Turn Only Espagnolette, 15 mm Backset, Zinc Gear 800, 700-1200	10070.0800.0.2
Tilt-Only / Turn Only Espagnolette, 15 mm Backset, Zinc Gear 1000, 900-1200	10070.1000.0.2
Tilt-Only / Turn Only Espagnolette, 15 mm Backset, Zinc Gear 1200, 1100-1400	10070.1200.0.2
Tilt-Only / Turn Only Espagnolette, 15 mm Backset, Zinc Gear 1400, 1300-1600	10070.1400.0.2
Tilt-Only / Turn Only Espagnolette, 15 mm Backset, Zinc Gear 1600, 1500-1800	10070.1600.0.2
Tilt-Only / Turn Only Espagnolette, 15 mm Backset, Zinc Gear 1800, 1700-2000	10070.1800.0.2
Tilt-Only / Turn Only Espagnolette, 15 mm Backset, Zinc Gear 2000, 1900-2000	10070.2000.0.2

# Sliding Espagnolette, 15 mm Backset Steel Gear

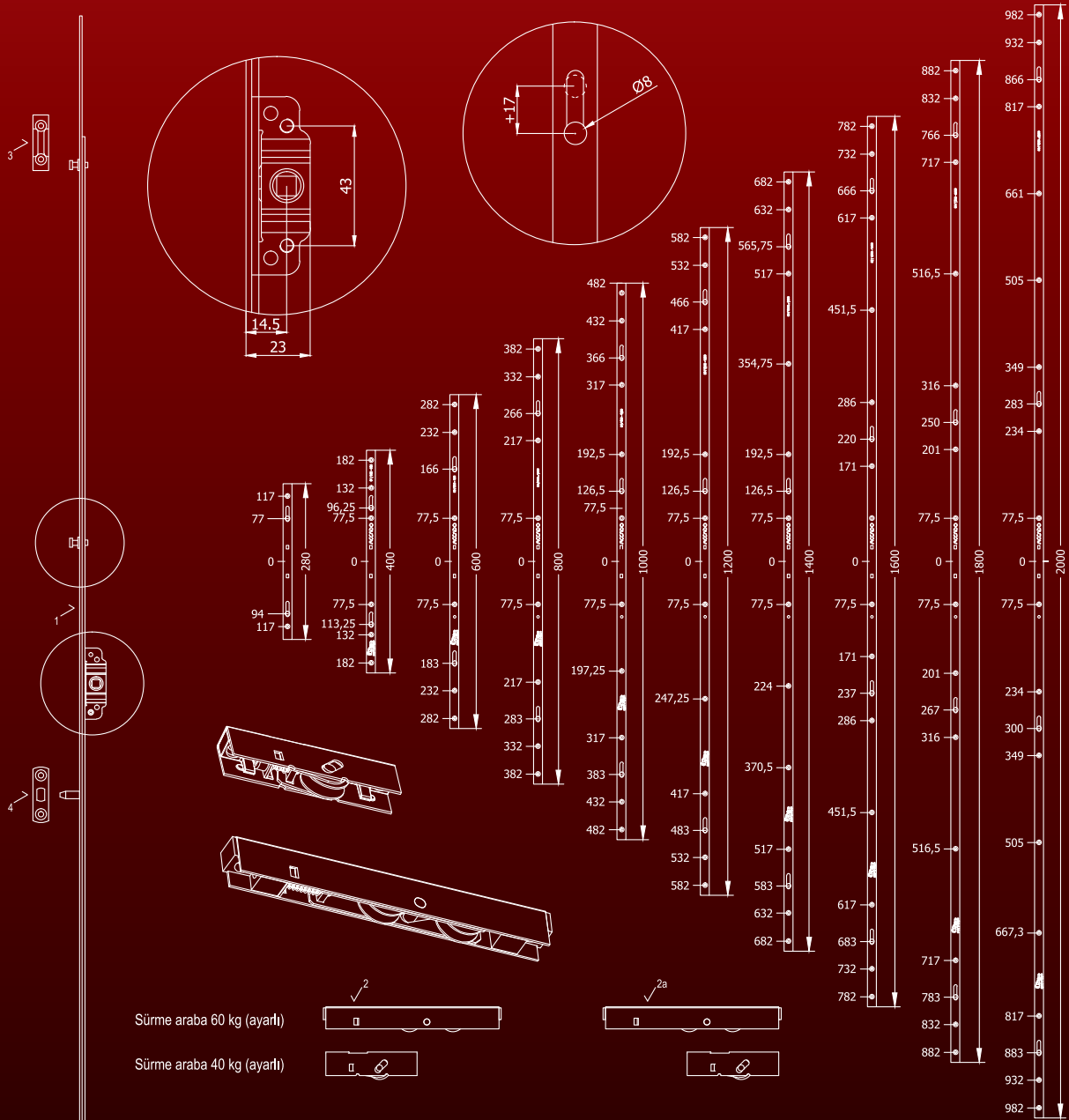

Sürme araba 60 kg (ayarlı)

Sürme araba 40 kg (ayarlı)

Description	Article Nr.
Sliding Espagnolette, 15 mm Backset Steel Gear 280, 280-400	10072.0280.0.2
Sliding Espagnolette, 15 mm Backset Steel Gear 400, 300-600	10072.0400.0.2
Sliding Espagnolette, 15 mm Backset Steel Gear 600, 500-800	10072.0600.0.2
Sliding Espagnolette, 15 mm Backset Steel Gear 800, 700-1200	10072.0800.0.2
Sliding Espagnolette, 15 mm Backset Steel Gear 1000, 900-1200	10072.1000.0.2
Sliding Espagnolette, 15 mm Backset Steel Gear 1200, 1100-1400	10072.1200.0.2
Sliding Espagnolette, 15 mm Backset Steel Gear 1400, 1300-1600	10072.1400.0.2
Sliding Espagnolette, 15 mm Backset Steel Gear 1600, 1500-1800	10072.1600.0.2
Sliding Espagnolette, 15 mm Backset Steel Gear 1800, 1700-2000	10072.1800.0.2
Sliding Espagnolette, 15 mm Backset Steel Gear 2000, 1900-2000	10072.2000.0.2
Adjustable Slide & Tilt Runner Set (2 Plastic Runner)	10239.0000.0.2
Adjustable Slide & Tilt Runner Set (2 Brass Runner)	10241.0000.0.2
Adjustable Slide & Tilt Runner Set (1 Plastic Runner)	10240.0000.0.2
Adjustable Slide & Tilt Runner Set (1 Brass Runner)	10242.0000.0.2
Locking Plate for Sliding Gear	10238.0000.0.2
Sliding Centering Piece	20311.0000.0.2



# Door Lock Systems



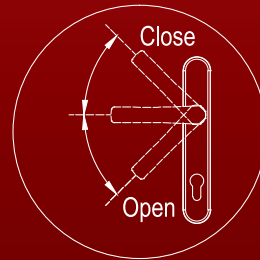

Description	Article Nr.	Type
35/85 Door Lock Gear 1600, 1600 - 1800	10036.1600.0.2	Standart
35/85 Door Lock Gear 1800, 1800 - 2000	10036.1800.0.2	Standart
35/85 Door Lock Gear 2000, 2000 - 2200	10036.200.0.2	Standart
28/85 Door Lock Gear 1600, 1600 - 1800	10037.1600.0.2	Standart
28/85 Door Lock Gear 1800, 1800 - 2000	10037.1800.0.2	Standart
28/85 Door Lock Gear 2000, 2000 - 2200	10037.2000.0.2	Standart
35/85 Door Lock Gear 1600, 1600 - 1800	10038.1600.0.2	Balcony
35/85 Door Lock Gear 1800, 1800 - 2000	10038.1800.0.2	Balcony
35/85 Door Lock Gear 2000, 2000 - 2200	10038.2000.0.2	Balcony
28/85 Door Lock Gear 1600, 1600 - 1800	10039.1600.0.2	Balcony
28/85 Door Lock Gear 1800, 1800 - 2000	10039.1800.0.2	Balcony
28/85 Door Lock Gear 1200, 1100-1400	10039.2000.0.2	Balcony
35/85 Door Lock Gear 1600, 1600 - 1800	10049.1600.0.2	Standart
35/85 Door Lock Gear 1800, 1800 - 2000	10049.1800.0.2	Standart
35/85 Door Lock Gear 2000, 2000 - 2200	10049.2000.0.2	Standart
28/85 Door Lock Gear 1600, 1600 - 1800	10050.1600.0.2	Standart
28/85 Door Lock Gear 1800, 1800 - 2000	10050.1800.0.2	Standart
28/85 Door Lock Gear 2000, 2000 - 2200	10050.2000.0.2	Standart

Description	Article Nr.	Type
Adjustable Door Locking Plate	10230.0000.0.2	Standart
Adjustable Door Locking Plate (Plastic)	10231.0000.0.2	Standart
Adjustable Door Locking Plate - Small	10234.0000.0.2	Standart

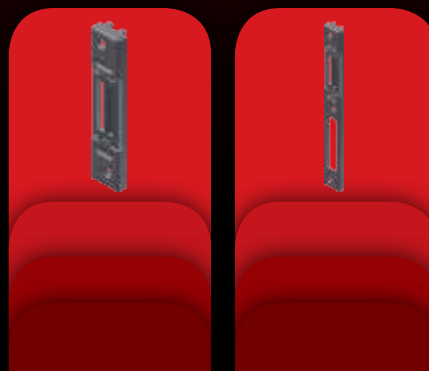
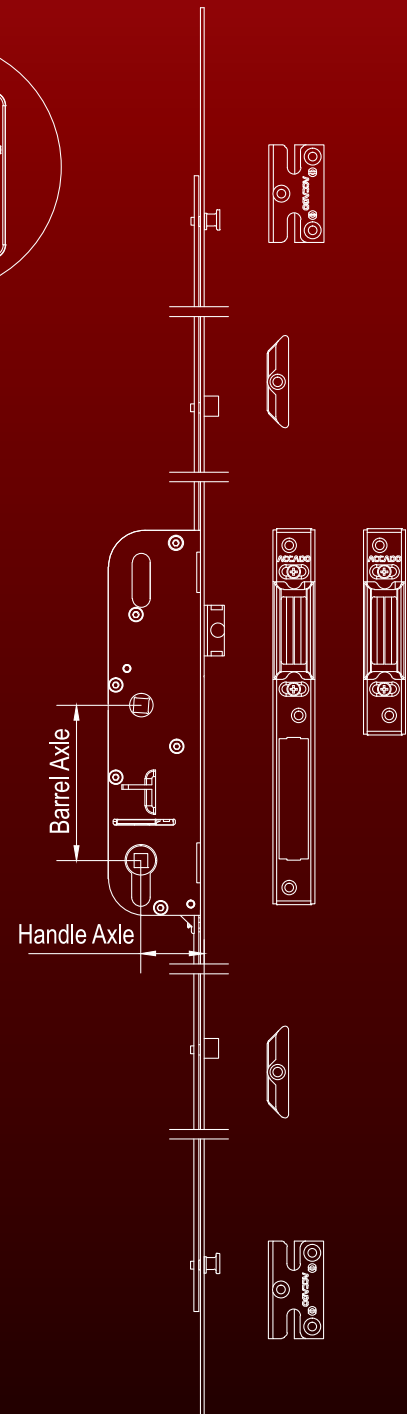

# Restrictor and Cleaning Stay Systems



# Restrictor and Cleaning Stays

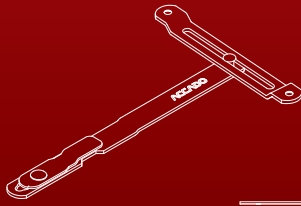

Espagnolette connected  
Restrictor and Cleaning Stay



Espagnolettes for Restrictor and Cleaning Stay

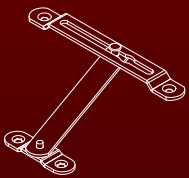

Restrictor and Cleaning Stay - 13 cm

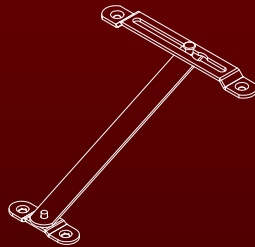

Restrictor and Cleaning Stay - 22 cm

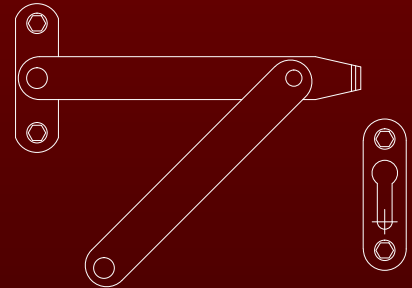

Restrictor and Cleaning Stay (fold)

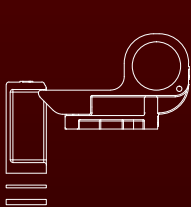

Window Catch

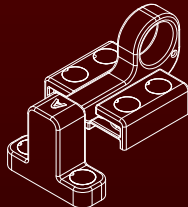

Adjustable Window Catch

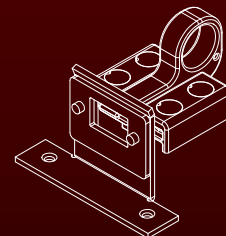
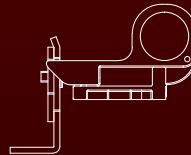

Espagnolettes for Restrictor and Cleaning Stays

Article Nr	Description
10249.0013.0.*	Restrictor and Cleaning Stay - 13 cm
10250.0022.0.*	Restrictor and Cleaning Stay - 22 cm
10251.0000.0.*	Restrictor and Cleaning Stay (fold)
10362.0000.0.*	Window Catch
10375.0000.0.*	Adjustable Window Catch
10388.0000.0.*	Espagnolette connected Restrictor and Cleaning Stay

Description	Article Nr.
Tilt-Only / Turn Only Espagnolette, 15 mm Backset - RCS - 400, 300-600	10395.0400.0.2
Tilt-Only / Turn Only Espagnolette, 15 mm Backset - RCS - 600, 500-800	10395.0600.0.2
Tilt-Only / Turn Only Espagnolette, 15 mm Backset - RCS - 800, 700-1200	10395.0800.0.2
Tilt-Only / Turn Only Espagnolette, 15 mm Backset - RCS - 1000, 900-1200	10395.1000.0.2
Tilt-Only / Turn Only Espagnolette, 15 mm Backset - RCS - 1200, 1100-1400	10395.1200.0.2
Tilt-Only / Turn Only Espagnolette, 15 mm Backset - RCS - 1400, 1300-1600	10395.1400.0.2

# Window Handles

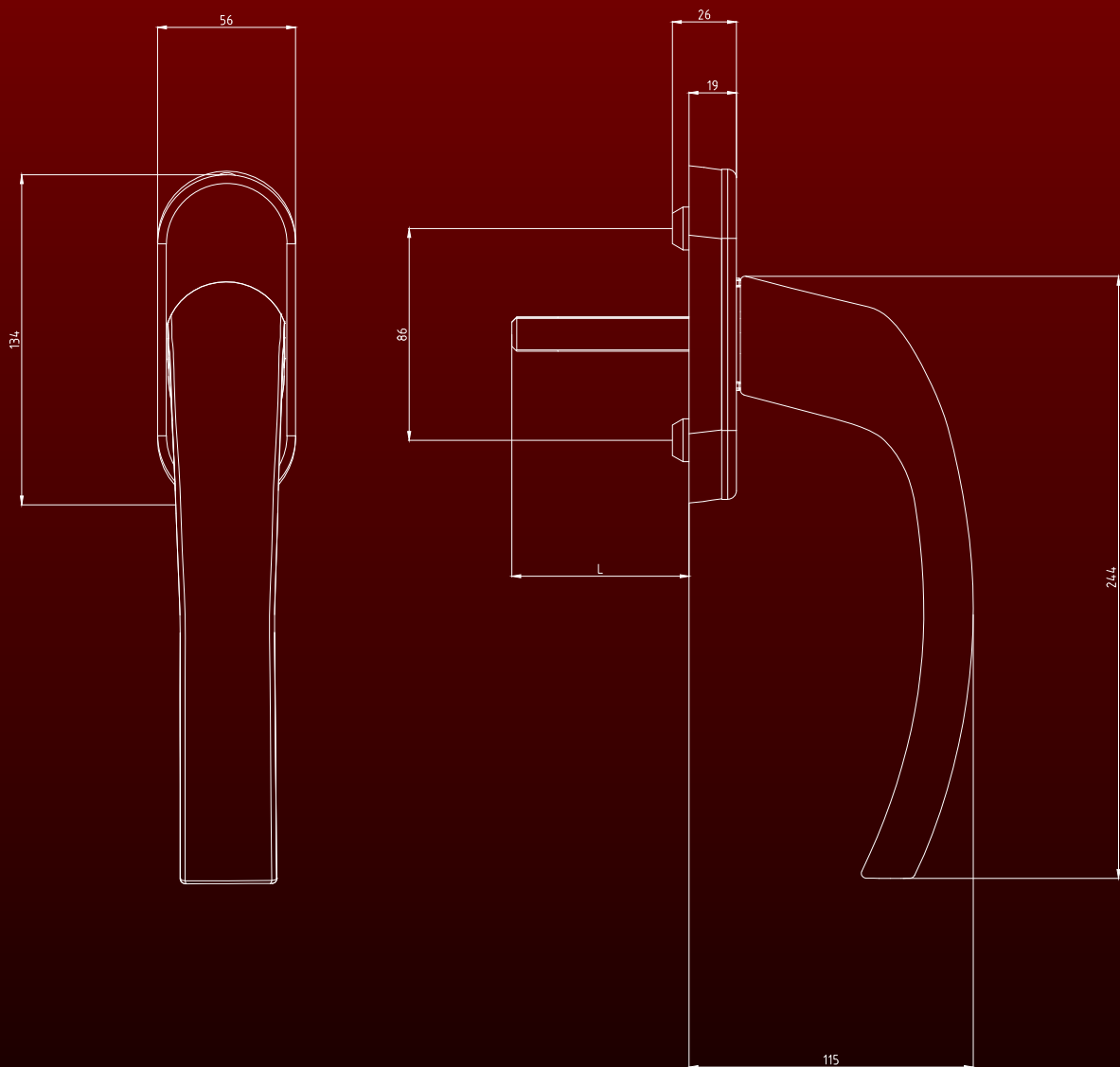

Article Nr	Description
10200.0033.0.*	Myra window handles, 33 mm
10200.0035.0.*	Myra window handles, 35 mm
10200.0038.0.*	Myra window handles, 38 mm

# Door Handles



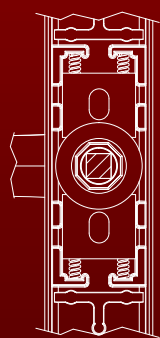

With spring

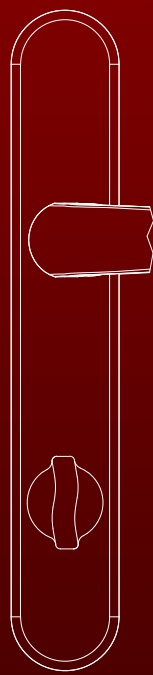

WC

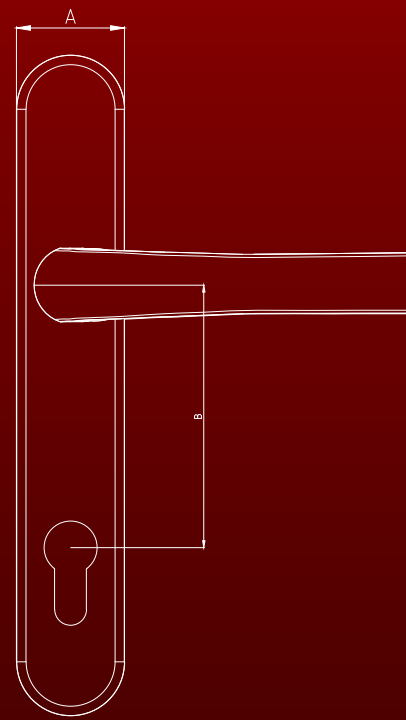

Standard

Article Nr	Description	Type	A	B
10160.0070.0.*	Myra door handle, 70 mm	Standard	35	70
10160.0085.0.*	Myra door handle, 85 mm	Standard	35	85
10160.0092.0.*	Myra door handle, 92 mm	Standard	35	92
10161.0070.0.*	Myra door handle, springed, 70 mm	Standard	35	70
10161.0085.0.*	Myra door handle with spring, 85 mm	Standard	35	85
10161.0092.0.*	Myra door handle with spring, 92 mm	Standard	35	92
10162.0070.0.*	Myra door handle, 70	Standard	28	70
10162.0085.0.*	Myra door handle, 85 mm	Standard	28	85
10162.0092.0.*	Myra door handle, 92 mm	Standard	28	92
10163.0070.0.*	Myra door handle with spring, 70 mm	Standard	28	70
10163.0085.0.*	Myra door handle with spring, 85 mm	Standard	28	85
10163.0092.0.*	Myra door handle with spring, 92 mm	Standard	28	92
10164.0090.0.*	Myra door handle WC	WC	35	90
10165.0090.0.*	Myra door handle with spring WC	WC	35	90
10166.0090.0.*	Myra door handle WC	WC	28	92
10167.0090.0.*	Myra door handle with spring WC	WC	28	70



# Door Handles

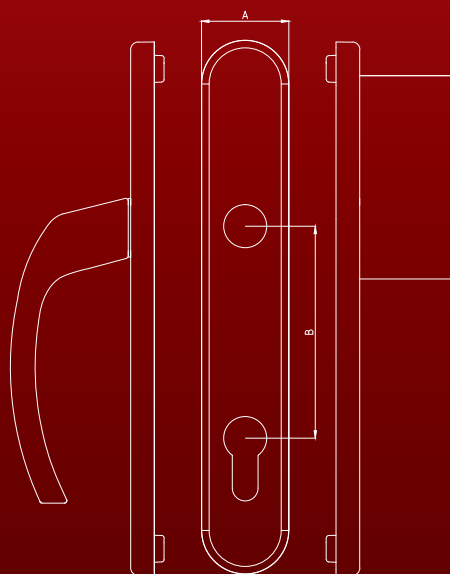

Pull door handle

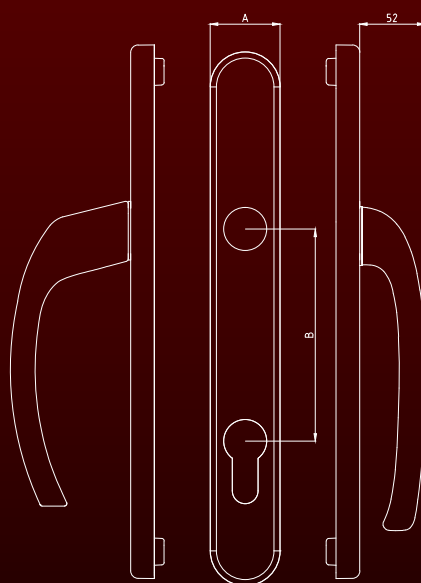

Shutter door handle

Article Nr	Description	Type	A	B
10270.0070.0.*	Myra pull door handle, 70 mm	Standard	35	70
10270.0085.0.*	Myra pull door handle, 85 mm	Standard	35	85
10270.0092.0.*	Myra pull door handle, 92 mm	Standard	35	92
10272.0070.0.*	Myra shutter door handle, 70 mm	Standard	28	70
10272.0085.0.*	Myra shutter door handle, 85 mm	Standard	28	85
10272.0092.0.*	Myra shutter door handle, 92 mm	Standard	28	92

**Hinges**



# 3D Adjustable Door Hinge

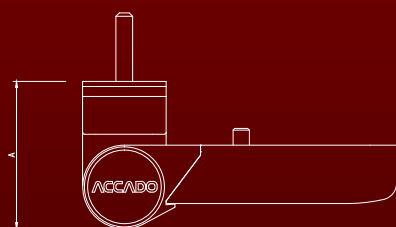
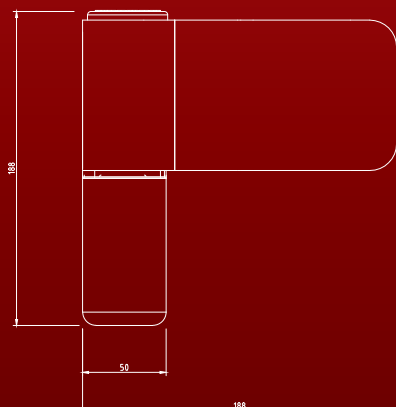

Overlap thickness	"A" dimension
12,3 - 16,3	39,3
16,3 - 20,3	43,8



Article Nr	Description
10024.0000.0.*	3D adjustable door hinge
10263.0000.0.9	Jig for 3D adjustable door hinge

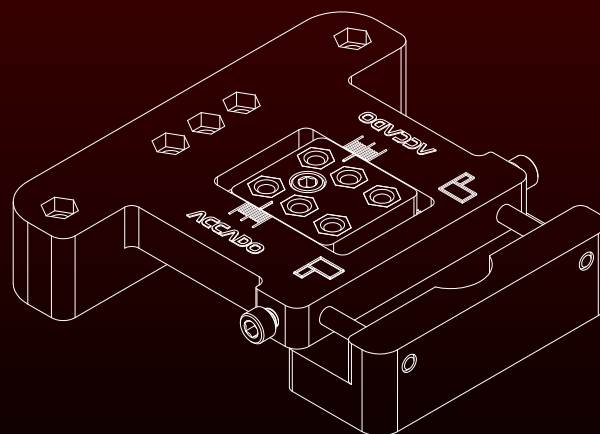
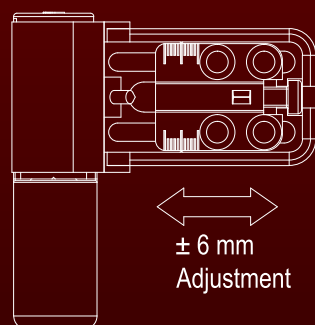
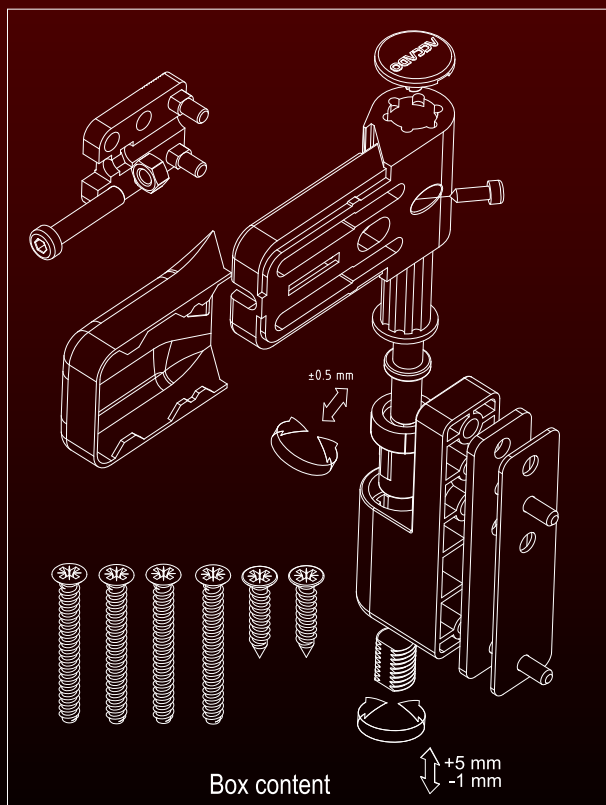

Jig for 3D adjustable door hinge

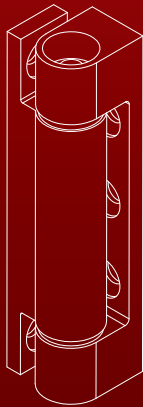

Hinge 75 mm

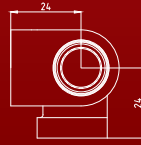

Article Nr	Description
10047.0075.0.*	75 mm Hinge
10215.0075.0.*	532 - 75 mm Hinge
10221.0090.0.*	532 - 90 mm Hinge
10047.0100.0.*	100 mm Hinge

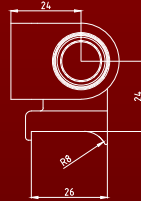

Article Nr	Description
10217.0075.0.*	632 - 75 mm Hinge
10220.0090.0.*	632 - 90 mm Hinge

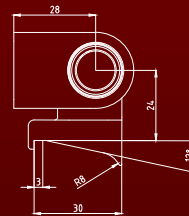

Article Nr	Description
10227.0075.0.*	752 - 75 mm Hinge
10224.0090.0.*	752 - 90 mm Hinge

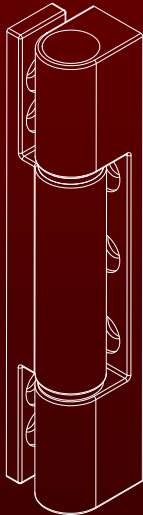

Hinge 90 / 100 mm

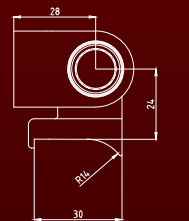

Article Nr	Description
10218.0090.0.*	80 - 90 mm Hinge

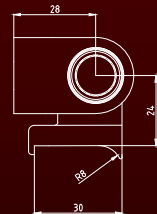

Article Nr	Description
10223.0090.0.*	752- Outside opening hinge 90 mm

Article Nr	Description
10214.0090.0.9	Jig for hinge

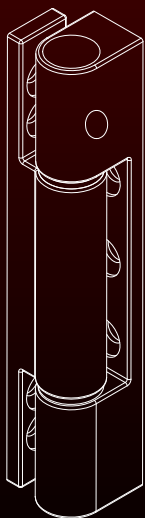

Outside opening hinge

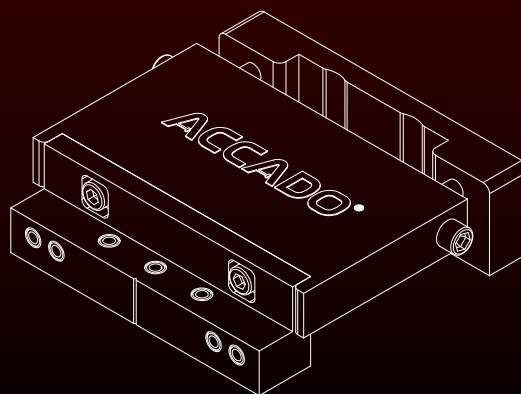

Jig for Hinge

